

Belt driven guided linear unit
 Linearantrieb mit Zahnriemen und integrierter Kugelumlaufführung
 Attuatori lineari a cinghia e guida a ricircolo di sfere

MTZ55S

TECHNICAL DATA - TECHNISCHE DATEN -- DATI TECNICI

Size - Baugröße - Taglia			55x55
Max. speed - Max. Geschwindigkeit - Velocità max		m/s	1
Max. stroke length - Max. Hub - Corsa max		mm	1500
Min. stroke length - Min. Hub - Corsa min		mm	100
Pulley drive ratio - Hub pro Umdrehung - Corsa/giro puleggia		mm	130
Number of teeth of pulley - Zähne der Riemenscheibe - nr. denti puleggia			26
Teeth belt with Steel Reinforced Polyurethane ATL 5 profile clearance 0, width 25 mm ATL-Profil Riemen 25 mm Breite- 5mm Achsabstand Tipo di cinghia profilo ATL passo 5 larghezza 25 mm			
Max rpm - Max. Drehzahl der Antriebswelle - Max nr. di giri in ingresso		g/min	460
Base weight - Gewicht bei 0mm Hub - Peso corsa 0 mm		Kg	5,1
Add for 100 mm of stroke - Gewicht bei 100mm Hub - Peso corsa 100 mm		Kg	0,6
Max. load* - Max. Belastung - Carico max*	Fx	N	1150
	Fy	N	7800
	Fz	N	7800
Moments* - Max. Belastungsmoment* - Momenti max*	Mx	Nm	395
	My	Nm	480
	Mz	Nm	480
Inertia moment Aluminum profile - Flächenträgheitsmoment - Momento d'inerzia profilo	Ix	cm ⁴	36
Inertia moment Aluminum profile - Flächenträgheitsmoment - Momento d'inerzia profilo	Iy	cm ⁴	46
Repeatability - Wiederholgenauigkeit - Ripetibilità		mm	± 0,05
Max. radial load on input shaft - Max. axiale Lasten an der Antriebswelle - Carico assiale max all'albero motore		N	200
No load torque - Leerlaufmoment - Coppia resistente		Nm	1

The moments and the loads above are max. values. For any further information, please contact our technical department.

Die angegebenen Momente und Belastungen sind max. Werte, die nicht überschritten werden sollen. Für weitere Info, bitte wenden Sie sich an unserem Konstruktionsbüro.

I carichi e i momenti indicati sono massimi consigliati, per ulteriori informazioni consultare il ns ufficio tecnico.

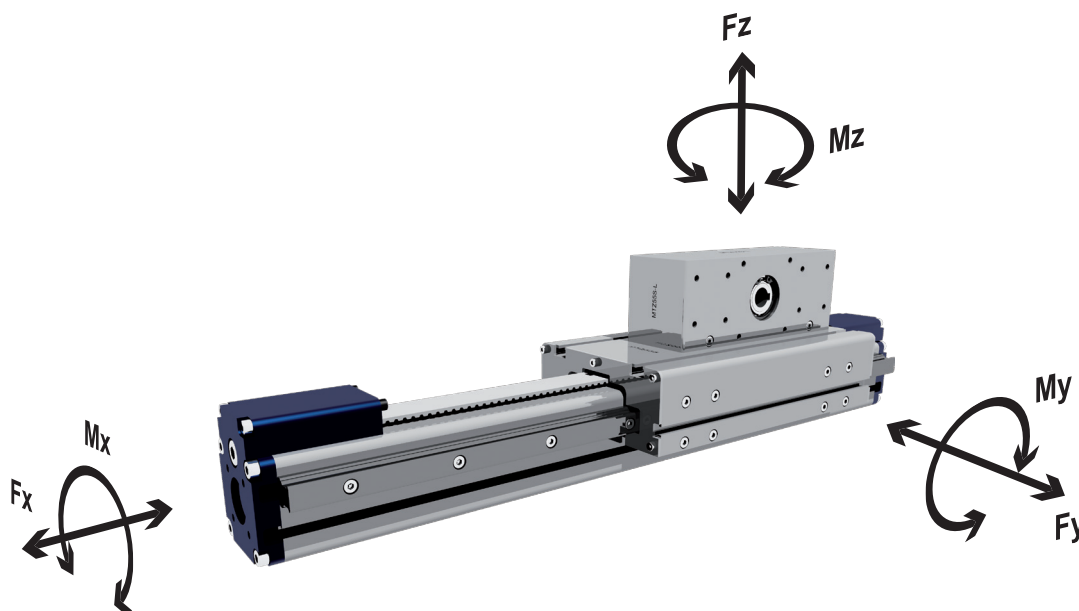

Motus Tech S.r.l. Motion Technology
 Via Leonardo da Vinci, 2
 I-24060 - Carobbio degli Angeli - Italy
 ph. +39 035 951138
 fax +39 035 4272018

www.motus-tech.com
info@motus-tech.com

Motus Tech UG
 Auf dem Brühl 6
 D-72658 Bempflingen - Germany
 Ph. +49 7123 32402
 Fax +49 7123 36580

Belt driven guided linear unit
 Linearantrieb mit Zahnriemen und integrierter Kugelumlaufführung
 Attuatori lineari a cinghia e guida a ricircolo di sfere



MTZ555

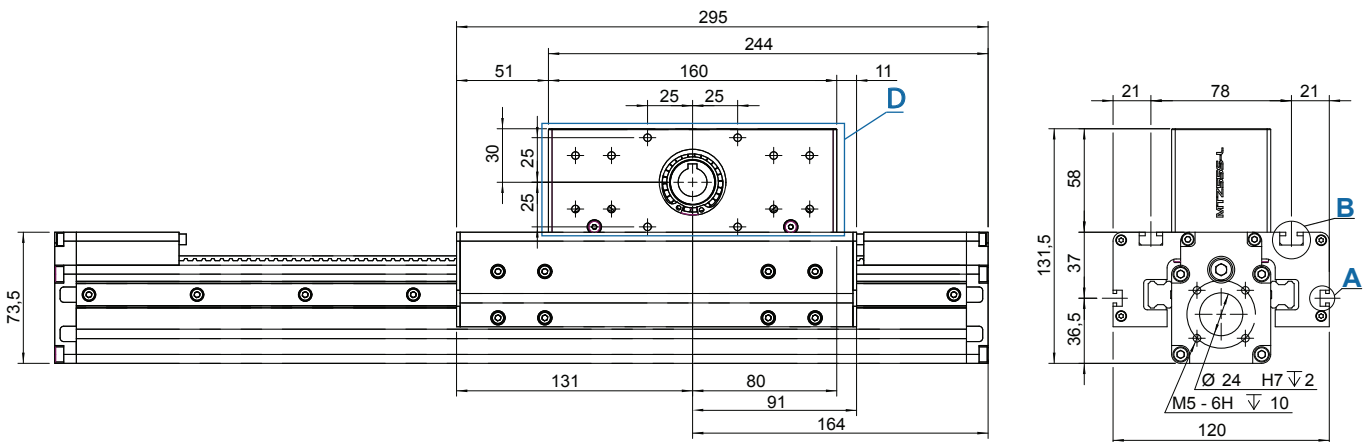

368 mm + corsa
 368 mm + stroke
 368 mm + hub

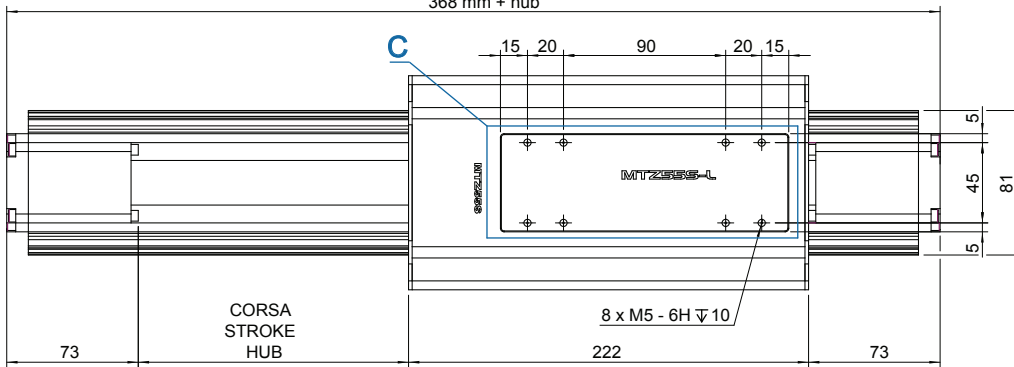

CORSA
 STROKE
 HUB

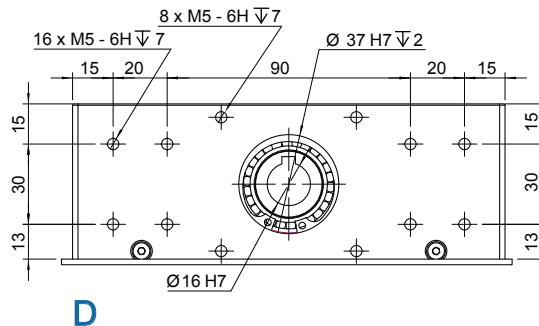
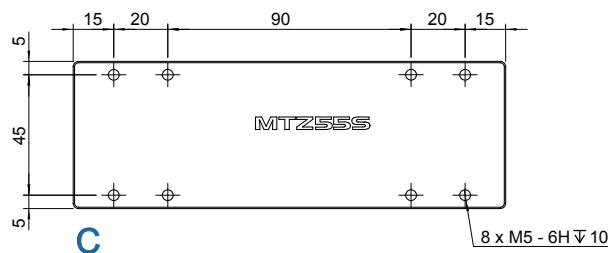
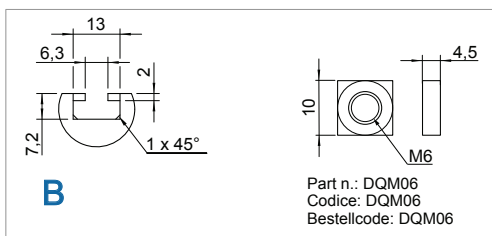
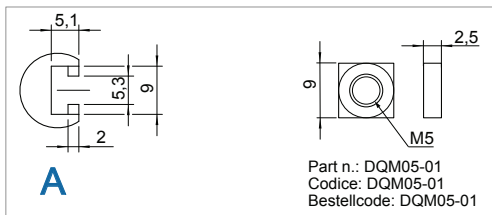

Motus Tech S.r.l. Motion Technology
 Via Leonardo da Vinci, 2
 I-24060 - Carobbio degli Angeli - Italy
 ph. +39 035 951138
 fax +39 035 4272018

www.motus-tech.com
 info@motus-tech.com

Motus Tech UG
 Auf dem Brühl 6
 D-72658 Bempflingen - Germany
 Ph. +49 7123 32402
 Fax +49 7123 36580